



SMARTMILL Series

SM 50 | SM 60 | SM 80 / 80 L | SM 60 APC

SMART MILL



HIGH PRODUCTIVITY MACHINING CENTRES

Shaping The Future By Shaping Metal

Cosmos is a CNC machine tool manufacturer established in 1987, focused on developing practical machining solutions for production environments. The company began with the supply of advanced vertical machining centres and later expanded into the **manufacturing of surface grinding machines, drill tap centres, vertical machining centres, vertical lathes, and other CNC solutions.**

Today, Cosmos provides machining solutions ranging from entry-level production machines to advanced technology platforms. Machine development focuses on rigidity, accuracy, and long-term stability to support consistent performance in production environments.

With manufacturing rooted in India's industrial strength and aligned with global standards, Cosmos focuses on delivering machining solutions that support long-term customer relationships. This approach is guided by the company's core values of

Integrity, Meritocracy, Respect for Individuals, Dynamic Thinking, Creativity & Innovation, and Social Responsibility.



Manufacturing Excellence

Cosmos Manufacturing Unit 1

Comprehensive Machining, Fabrication & Assembly Hub

This facility forms the backbone of our manufacturing excellence, producing high-performance CNC machines with industry-leading accuracy and reliability.

Manufacturing Footprint

~15 acres

Workforce

~1200

Skilled Professionals



Cosmos Manufacturing Unit 2

Heavy Machinery Manufacturing & Final Integration

This unit plays a critical role in ensuring that every Cosmos machine delivers superior performance, longevity, and precision.

Manufacturing Footprint

~2.5 acres

Upcoming Manufacturing Facility

~25 acres

Workforce

~250 Skilled

Professionals



OUR MANUFACTURING PROCESS

Casting



Machining



Fabrication



Powder Coating



Frame Assembly



Sheet Metal Assembly



Electrical & Controller Assembly



Final Machine Assembly & Dispatch



Why Smartmill ?

Engineered for Structural Integrity

Optimized casting design and rigid construction ensure consistent accuracy under real production conditions.

Precision You Can Repeat

High stiffness and thermal stability deliver reliable accuracy from first component to batch production.

High-Speed, Controlled Machining

Optimized motion system enables faster cycle times while maintaining surface finish and dimensional control.

Backed by Cosmos Expertise

Supported by a strong service network, application knowledge, and long-term customer commitment.



Rapid Traverse
48 m/min

Spindle Speed
8000 rpm

Tool to Tool
2 sec.

Structural Architecture

A solid machine body with built-in components for better strength and reliability.



SM 60 APC



SM 50 / 60



SM 80 / 80L

Key Features

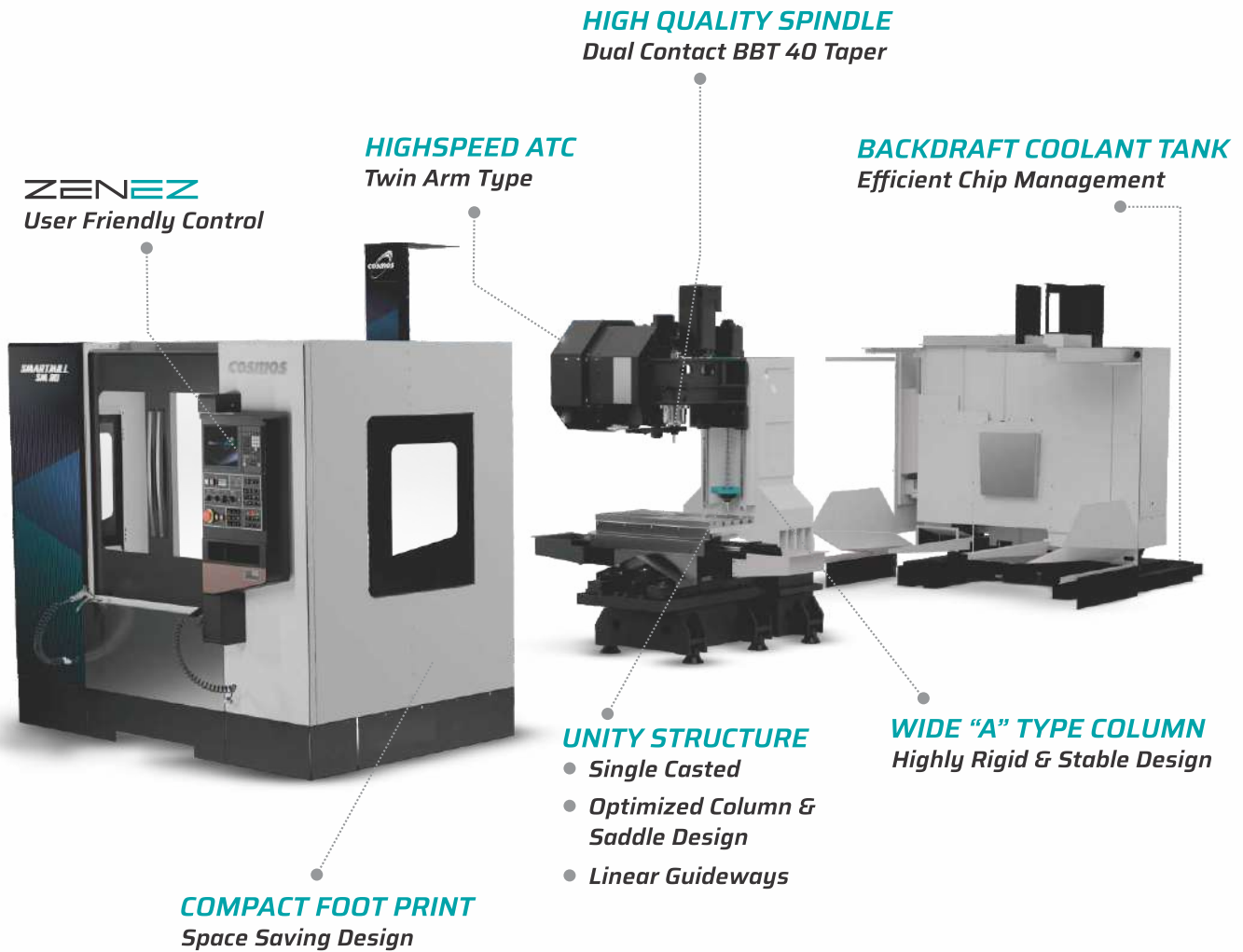

- Less Joints for Better Alignment.
- Fewer Parts Used for stronger structure.
- More Stable During Operation.
- Less Maintenance Required.

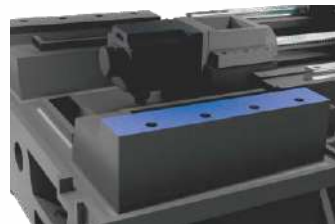

Hand scraped & Blue Matching

BBT-40 Spindle

Belt Drive



8,000 rpm (Std.) 10,000 rpm (Opt.)

Direct Drive



10,000 rpm (Opt.) 12,000 rpm (Opt.)

High Performance Spindle

- Powerful integrated 40 Taper dual contact spindle.
 - Standard Belt drive 8,000 rpm and optional 10,000 rpm with permanent grease.
 - Optional direct drive spindle 10,000 / 12,000 rpm with oil chiller.
 - CTS (Coolant through spindle) design to sustain upto 20 bar.
- *CTS system is optional.*

MULTIPURPOSE APPLICATIONS



Heavy Cutting

High Speed Milling

High Resolution Cutting

High Speed Tapping

MAXIMUM PRODUCTIVITY

Inbuilt tank mounted CTS system

*Through coolant increases tool/ life,
allows higher cutting speed and
clears chips during deep hole drilling.*

CTS system with

max. 20 bar pressure

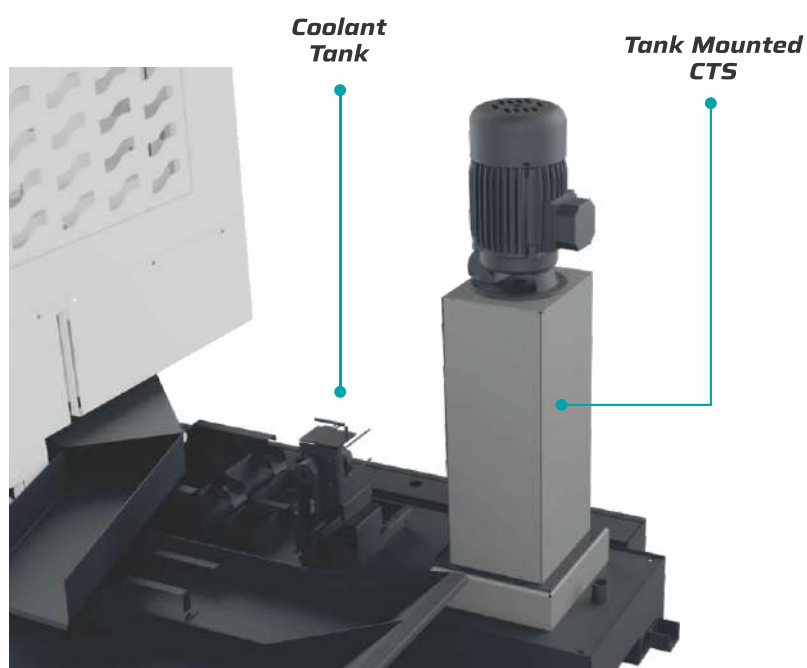

Spindle Options

Mitsubishi Controller

Standard

Belt Drive

8,000 rpm

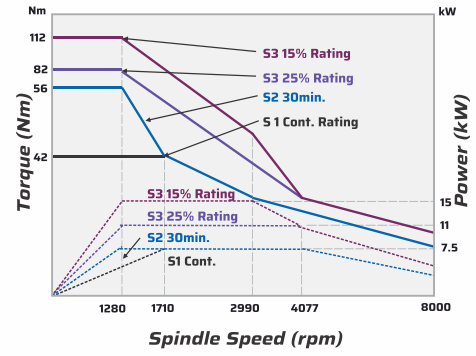
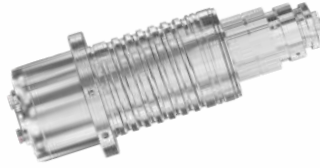

Optional

Belt Drive

8,000 / 10,000 rpm

Optional

Direct Drive

10,000 / 12,000 rpm

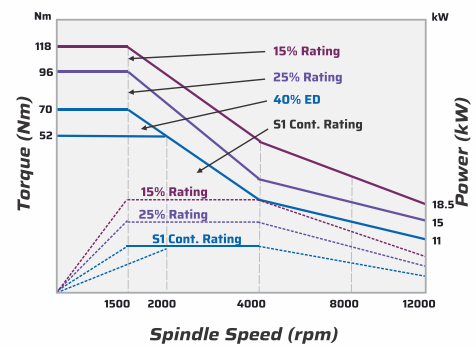

Fanuc Controller

Standard

Belt Drive

8,000 rpm

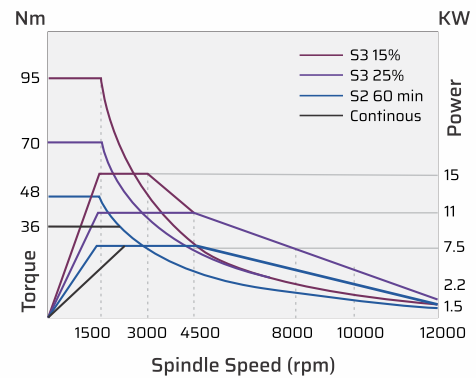
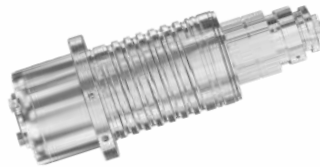

Optional

Belt / Direct Drive

10,000 / 12,000 rpm

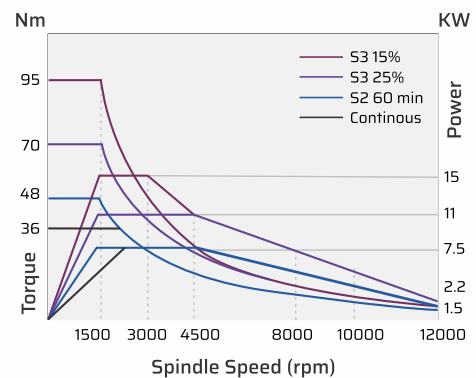

Chip Management System

An efficient system designed to remove chips continuously and keep the machine clean during operation.

- *Continuous Chip Removal for uninterrupted machining.*
- *Coolant-Assisted Chip Flushing for better cleaning.*
- *Reduced Chip Accumulation inside the machine.*
- *Easy Maintenance and Cleaner Workspace.*

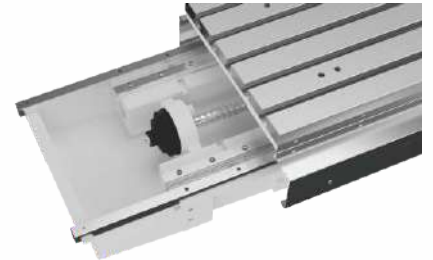
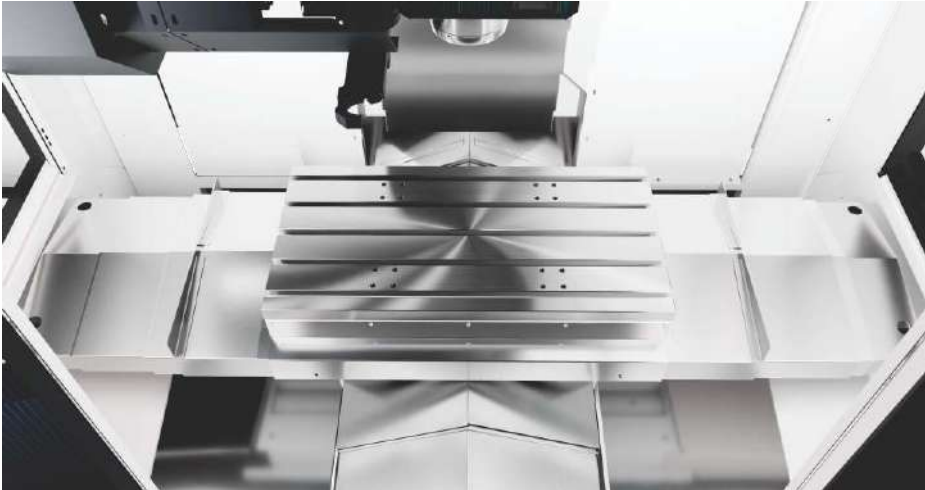

Bottom Cover

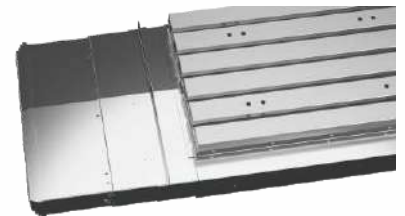

Telescopic Cover

Automatic Tool Changer

A high-speed automatic system that quickly and reliably changes tools to improve machining efficiency.

- *Fast and Accurate Tool Changing for higher productivity.*
- *Double-Arm Mechanism for smooth and secure tool handling.*
- *Handles Heavy and Large Tools with ease.*
- *Reduced Vibration During Tool Change for better accuracy.*
- *Quick Recovery Function via HMI to reduce downtime.*

HIGH SPEED ATC
Tool to Tool **2** Sec

AUTOMATIC TOOL CHANGER

Arm Type (SM 50/60)
2 Seconds (Tool to Tool)
24 Tools Storage (Standard)

Arm Type (SM 80)
2 Seconds (Tool to Tool)
30 Tools Storage (Standard)

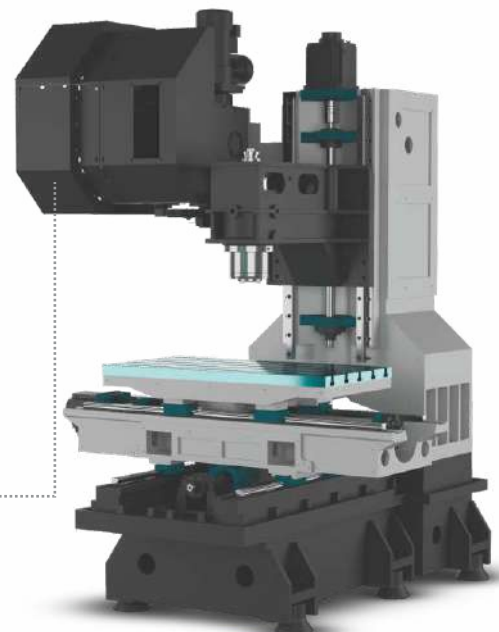

Ergonomics

A user-focused machine design that improves operator comfort, safety, and ease of use.

- Wide Front Access Door for easy loading and unloading.
- Smooth Door Operation with minimal effort.
- LED Work Lights for clear visibility during operation.
- Easy Access to Service Points for quick maintenance.
- Reduces Operator Fatigue and improves productivity.



Adaptive Feed Control

Boost your profitability by achieving the maximum with ease.

- It is one of the methods of adaptive control based on the velocity control to maintain a constant load on the cutting tool during machining.
- It offers productivity improvement by reducing the cycle time.
- It offers an improvement in tool life.
- It can be commanded with tool maximum load and minimum load monitoring.
- These combined features will change the machining environment to "reduction in cycle time" as well as to "faster reaction on the tool state".

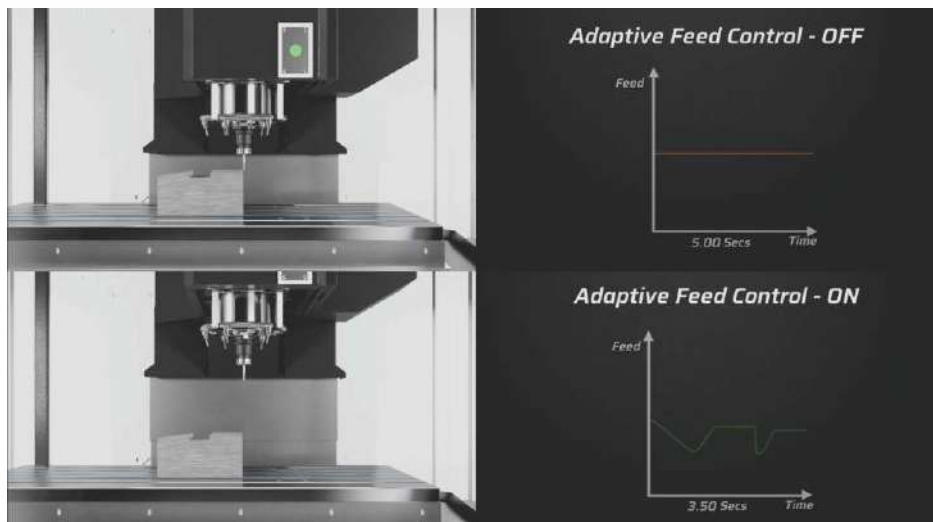

High Productivity Machining Centers

Core Design & Performance Highlights

Powerful

High-rigidity BBT 40 spindle for consistent performance

High Feed

Optimized feed rates for faster material removal

Strong

High-grade FG 260 & 300 casting for minimized vibration

Compact

Space-efficient design with operator-friendly layout

Stability

Wide "A" type column

Shimless Assembly

Hand scraped & Blue Matching

Smart Control

Advanced control system for seamless operation

Advanced

Integrated APC for higher productivity

Reliable

Built for long-term, consistent performance

SMARTCONNECT⁺

Easy smart connectivity to mobile app

Cosmos HMI

Easy Touch Screen Interface

10.4" Touch Screen

Smart Status View for Easy Operation

Smart Connect



SmartConnect+ provides real-time machine monitoring and comprehensive plant reporting from any location, enabling higher visibility and improved productivity on the go.



ZENCODE

CNC Milling 2.5D CAM Productivity Software **Easy | Smart | Economic | Versatile**

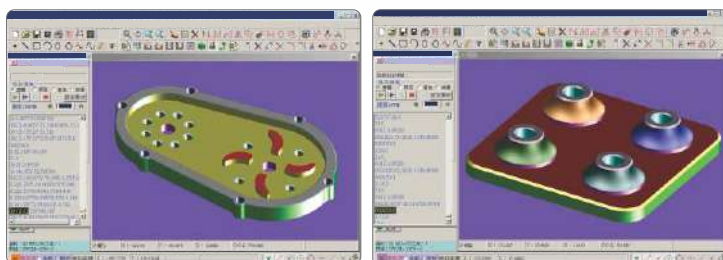

Key Features

- 2.5D machining
- Pocket milling
- Contour milling
- Toolpath for engraving
- All drilling, boring & tapping
- Facing
- Threadmill cycle
- Spiral machining
- Rest machining
- Tool library creator

*Available as option.

Machine User Interface ZENEZ HMI

Boost Your Profitability by Achieving the Maximum Performance with Ease.

It focuses on customised dashboards and tools that help the operator to simplify his daily activity. The overall feature and package can reduce the time lost due to the complexity of the controller GUI; as a result, Zenez can significantly increase the machine output and profitability.

- 10.4-inch display or 15-inch display.
- Fully functional vertical and horizontal soft-keys for non-touch usage.
- Crystal type Machine Operating Panel.



FANUC



Quick Access Menu
Easy Configuration

Expandable Memory
USB and Ethernet Port
Available

Custom Backlit Keys
with Hard Crystal Finish

Smart Status View for
Easy Operation

Full Keyboard with
Qwerty Keyboard



Scroll
Scroll in lists - Tool & Work offset list,
Program, Gcode List Parameter.



Tap
Tap to move the cursor or navigate
through the menus.



Pinch
Zoom in and out of graphic content
during simulation mode.



History



Diagnosis



User Manager



Cycle Time
Analysis

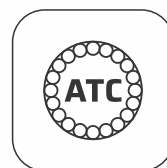

Tool Magazine
Management



Preventive
Maintenance
Checklist

Accuracy

Ball Bar Calibration Test

- Ball bar test (300 mm dia.) with circularity within 10µm.
- Every machine is Tested and calibrated.
- Ball bar testing for circularity verification.

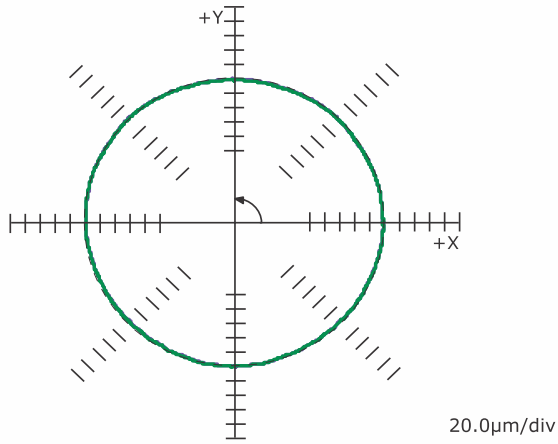

BALL BAR CALIBRATION STANDARD : ISO 230-4:2005



Ball Bar Calibration Test

Item (Ball Bar Test)	
ISO 230-4	SM Series
Radius	150.00mm
Sampling Feedrate	1200 mm/min
Circularity	<-0.010mm
Max. Reversal	<0.002mm

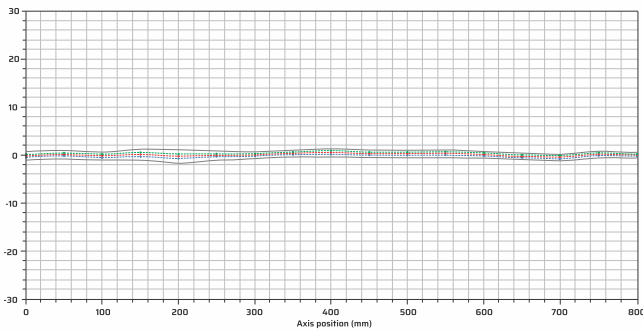

LASER CALIBRATION STANDARD : VDI 3441

Laser Test

- Laser calibration done in 5 **alternate bidirectional** passes.
- Laser calibration test with full stroke travel.
- Smooth and stable machine motion validation.
- Close to zero backlash for high repeatability.

Item (Pitch Error compensation)		Cosmos standard Tolerance SM Series
VDI/DGQ 3441		
Positional Uncertainty	P	<= 0.010 mm
Mean Positional Scatter	PS mean	<= 0.006 mm
Reversal Error	U max	<= 0.005 mm
Positional Deviation	PA	<= 0.003 mm

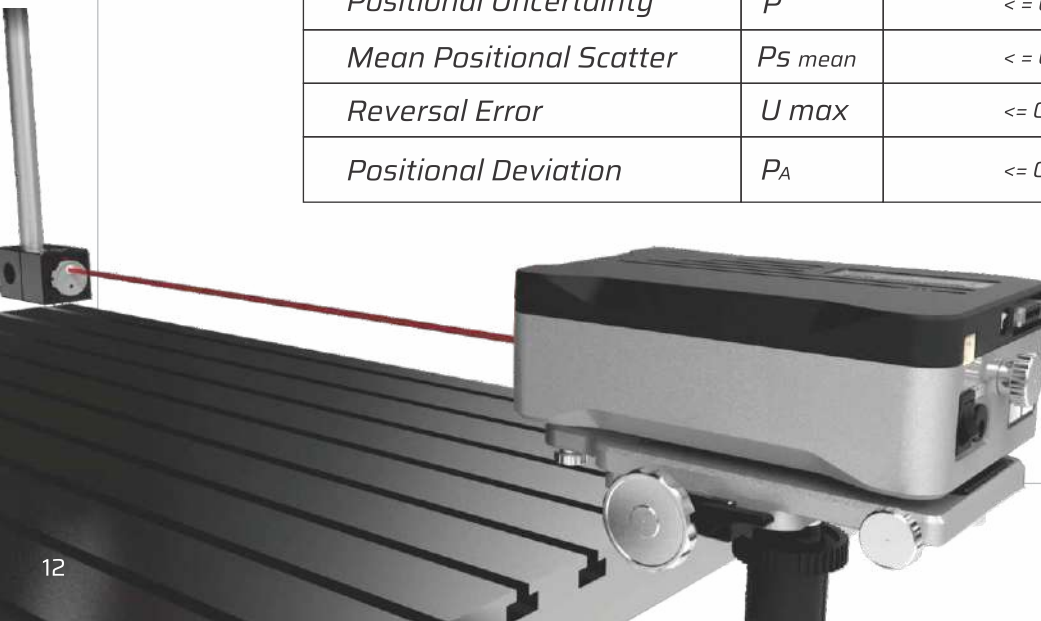

Machining Capacity

Factory Conditions

BBT-40 TAPER BELT DRIVE SPINDLE On Ch5 material SM 50 / SM 60



FACE MILL		MATERIAL REMOVAL	SPINDLE LOAD
Tool	63 mm	337 cc/min	75%
Cut (Width x Deep)	40 x 3.5		
Feedrate	2550mm/min		
Spindle Speed	1500rpm		

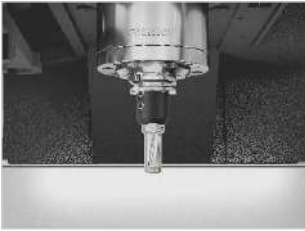

DRILL		MATERIAL REMOVAL	SPINDLE LOAD
Tool	40 mm	226 cc/min	70%
Cut (Deep)	30mm		
Feedrate	180mm/min		
Spindle Speed	1500rpm		



TAP		MATERIAL REMOVAL	SPINDLE LOAD
Tool	M20 x 2.5mm	-	80%
Spindle rpm	300rpm		
Feedrate	750mm/min		
Depth of Tap	2.5mm		

BBT-40 TAPER BELT DRIVE SPINDLE On MS material SM 80 / SM 80L



FACE MILL		MATERIAL REMOVAL	SPINDLE LOAD
Tool	63 mm	167 cc/min	46%
Cut (Width x Deep)	40 x 5.5		
Feedrate	800mm/min		
Spindle Speed	1500rpm		



DRILL		MATERIAL REMOVAL	SPINDLE LOAD
Tool	40 mm	237 cc/min	45%
Cut (Deep)	30mm		
Feedrate	188mm/min		
Spindle Speed	1500rpm		



TAP		MATERIAL REMOVAL	SPINDLE LOAD
Tool	M24 x 3mm	-	70%
Spindle rpm	300rpm		
Feedrate	124mm/min		
Depth of Tap	20mm		

SMARTMILL 50



MACHINE DIMENSIONS

Unit : mm

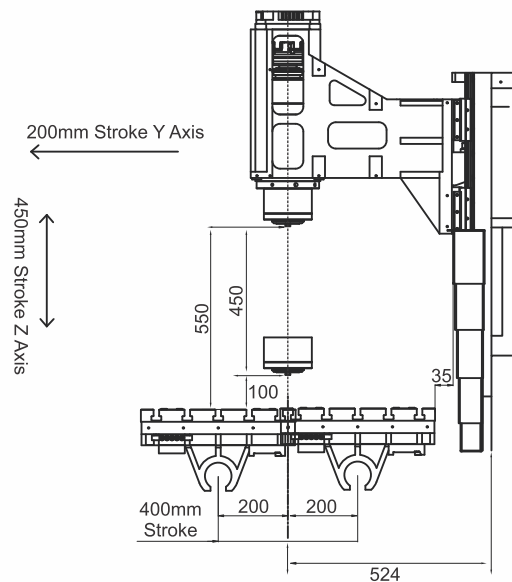
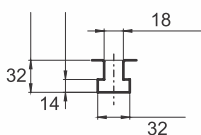
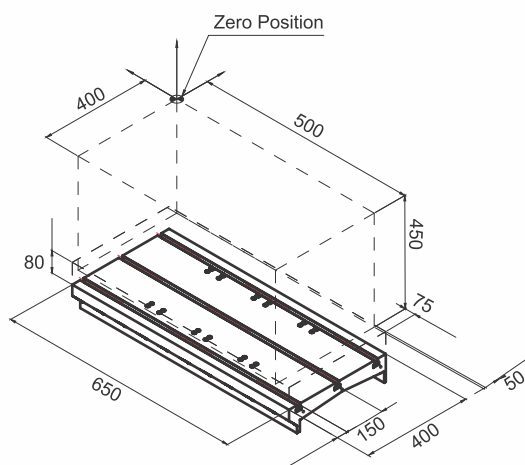
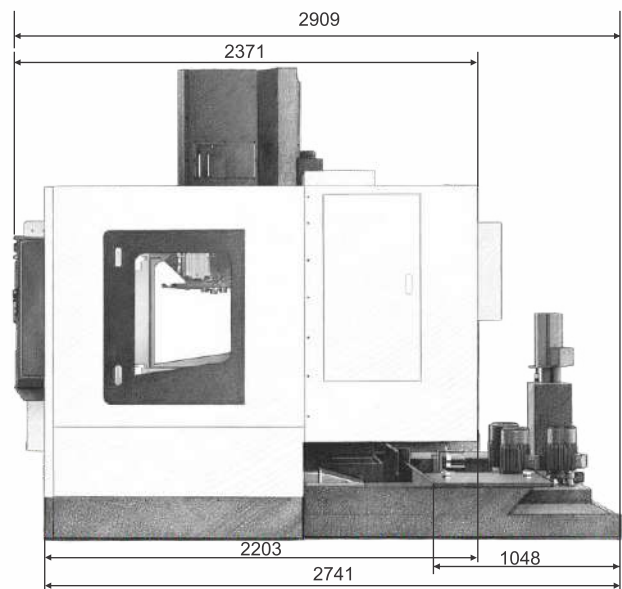
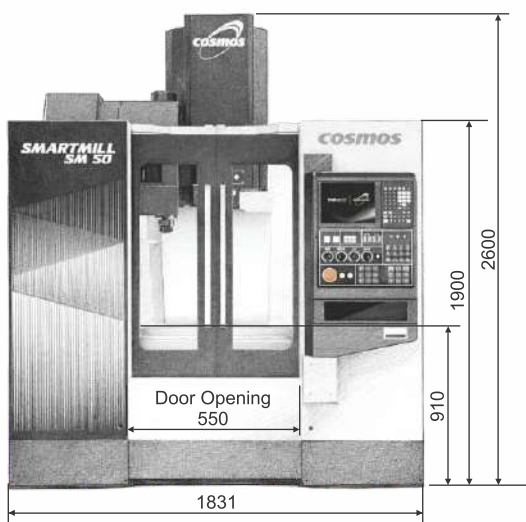

SMARTMILL 60



MACHINE DIMENSIONS

Unit : mm

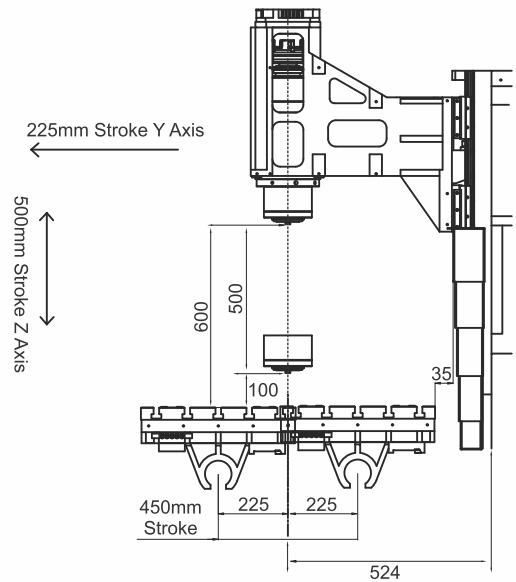
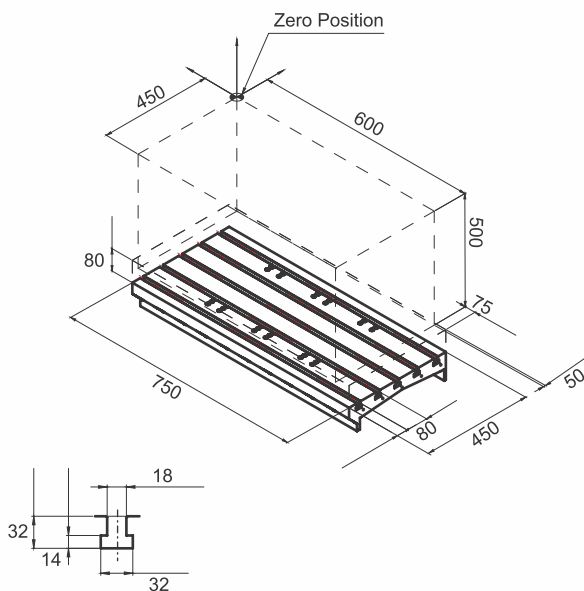
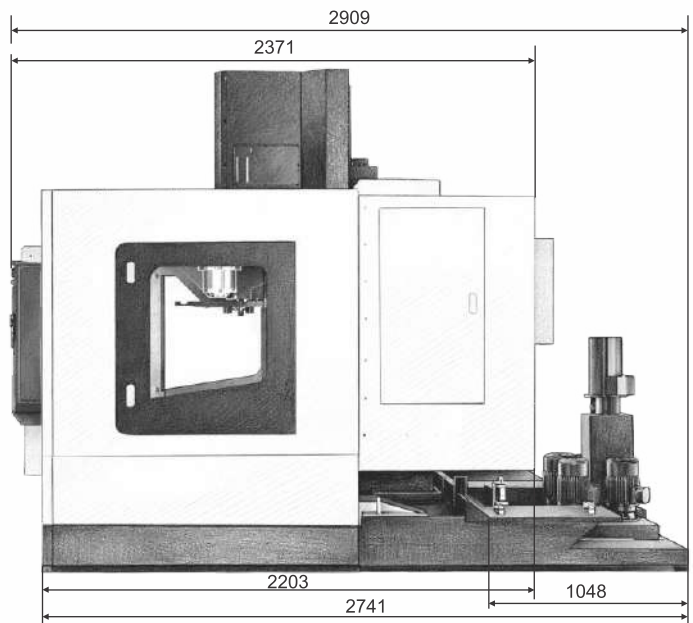
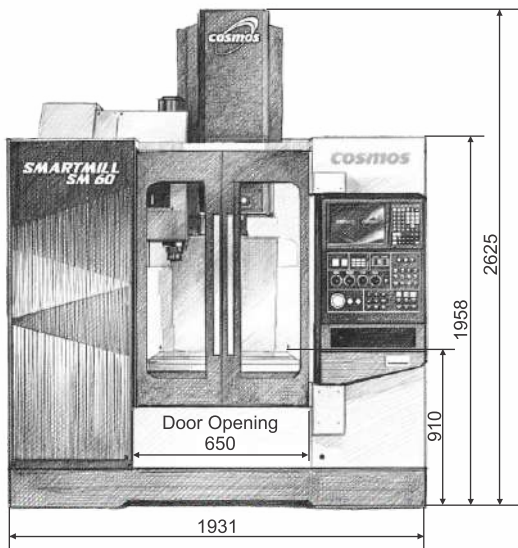

SMARTMILL 60 APC



MACHINE DIMENSIONS

Unit : mm

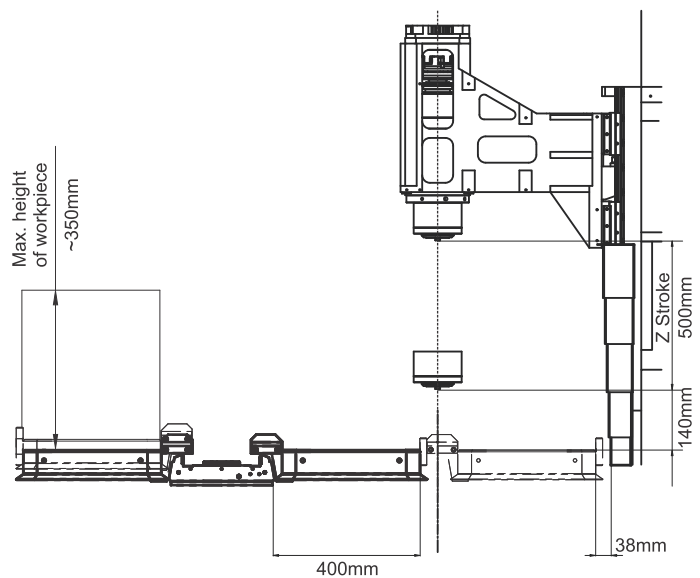
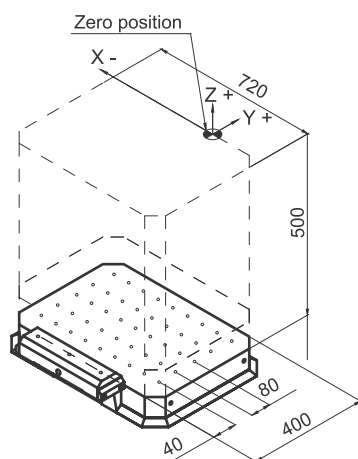
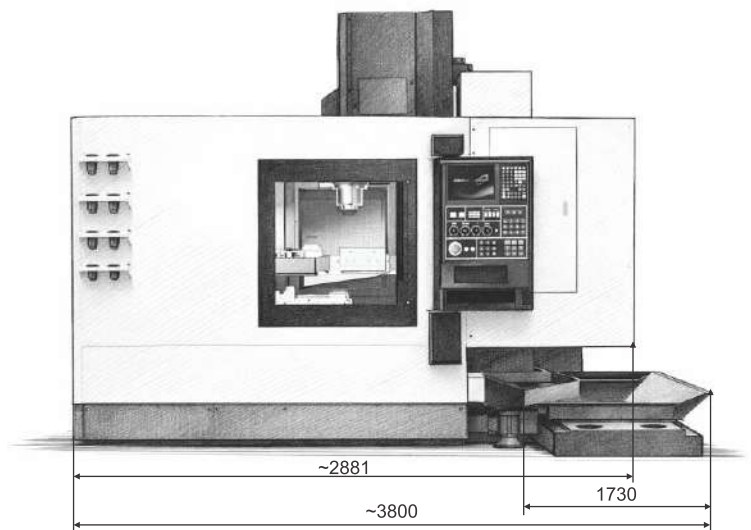
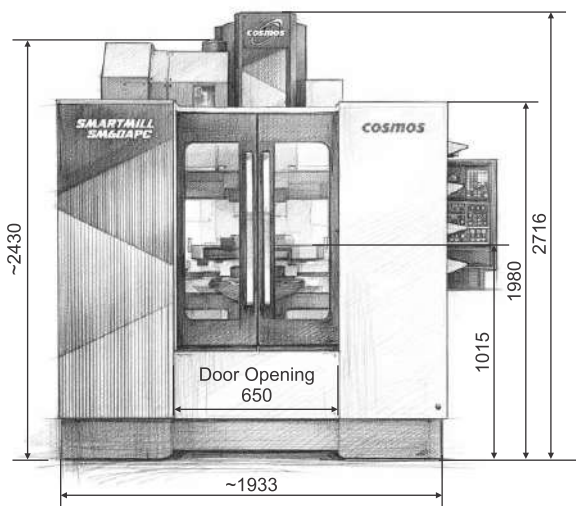

SMARTMILL 80



MACHINE DIMENSIONS

Unit : mm

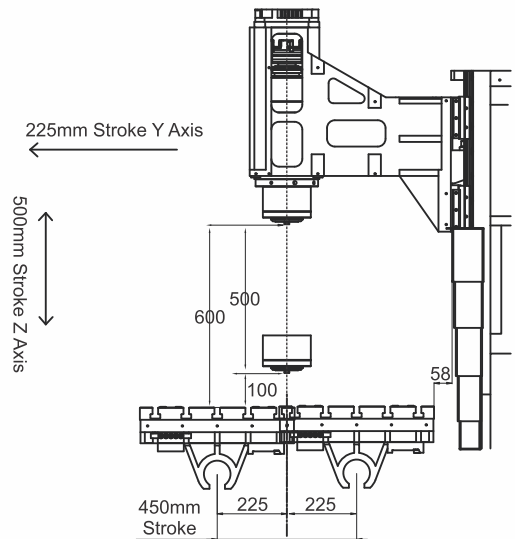
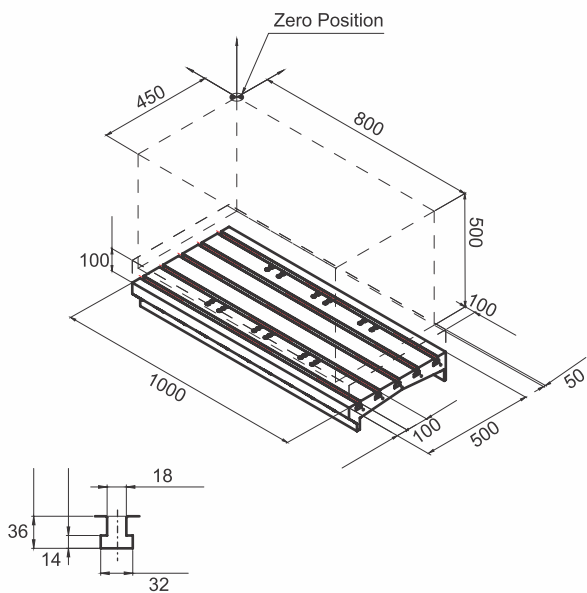
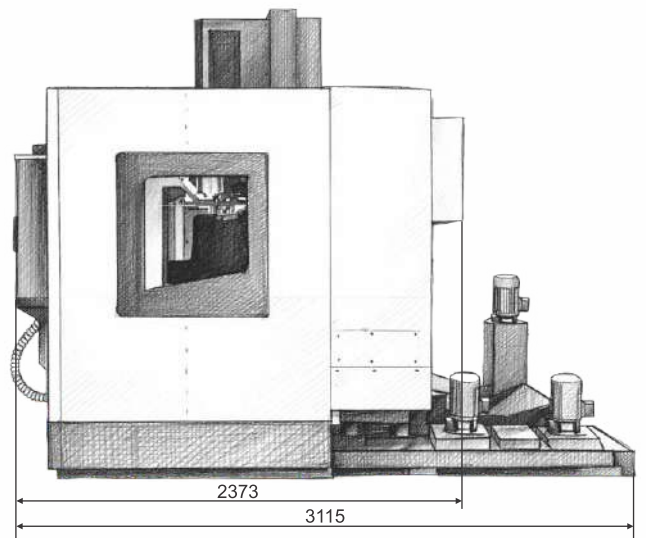
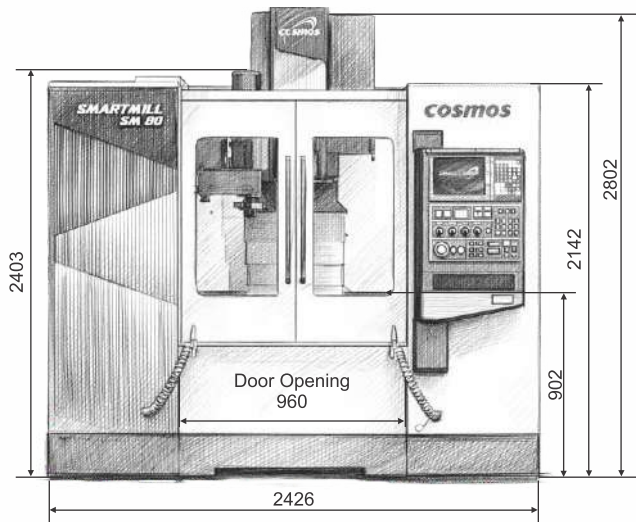

Specification

Description	Units	SM 50	SM 60	SM 80/80L
Travel				
X-Axis	mm	500	600	800
Y-Axis	mm	400	450	450/500
Z-Axis	mm	450	500	500
Table				
Spindle Nose to Table Surface	mm	100-550	100-600	100-600
Table Size	mm	650 x 400	750 x 450	1000 X 500
No/Width/CD of T-Slots	mm	3 x 18 x 150	5 x 18 x 80	5 x 18 x 100
Max. Loading Capacity	kg	300	300	560
Spindle				
Spindle Motor Output	kW	7.5/11/15	7.5/11/15	11/15/18.5
Spindle Max Speed	rpm	8000	8000	8000
Spindle Taper		BBT40	BBT40	BBT40
Feed				
Rapid Feed of X Axis	m/min	48	48	48
Rapid Feed of Y Axis	m/min	48	48	48
Rapid Feed of Z Axis	m/min	48	48	48
Cutting Feed Rate	m/min	0-10	0-10	0-10
ATC				
Tool Storage	nos	24 T	24 T	30 T
Max. Tool Diameter	mm	80	80	80
Max. Tool Length	mm	200	250	250
Max. Tool Weight	kg	8	8	8
Tool Change Time (Tool-to-Tool)	sec.	2	2	2
Accuracy				
Positioning	mm	0.010	0.010	0.010
Repeatability (+/-)	mm	± 0.003	± 0.003	± 0.003
General				
Floor Space (LxD)	mm	~1831 X 2741	~1931 X 2741	~2426 X 3115
Weight	kg	~3700	~3900	~4450
Power Capacity	kVA	25	25	30



Description	Units	SM 60 APC
APC		
Pallet Dimension	mm	720 x 400
Max. Load on Pallet	kg	200 x 2
Table T-slot	-	Table is tapped hole type with M10 tapping
APC Type	-	Swing Type Rotary
Pallet Change Time	sec.	11-13
Pallet Change Mechanism	-	Hydraulic
Pallet Clamping Mechanism	-	Hydraulic
Pallet Positioning	-	Taper Cone

Note: Specifications and features are subjected to change without prior notice. Please refer the offer document, offer document as precedence. Contact sales team for more accessories and tooling-up proposal

Standard / Optional Features

● Standard ○ Optional - Not Available

		SM 50	SM 60	SM 60 APC	SM 80	SM 80L
Spindle	8,000 rpm Belt Drive BBT 40 Taper	●	●	●	●	●
	10,000 rpm Belt Drive BBT 40 Taper with Spindle Oil Cooler	○	○	○	○	○
	10,000 / 12,000 rpm Direct Drive BBT 40 Taper with Spindle Oil Cooler	○	○	○	○	○
Controller	Mitsubishi M80 BV / Fanuc OiMF / Siemens Controller with 10.4" Display	●	●	●	●	●
	Mitsubishi M80 BV / Fanuc OiMF / Siemens Controller with 15" Display	○	○	○	○	○
	Siemens 828D Controller with 10.4"/15" Display*	○	○	○	○	○
	On special req. Heidenhain TNC7 Controller with 15" Display*	○	○	○	○	○
	Zenez HMI	●	●	●	●	●
	Heat Exchnager For Electric Cabinet	●	●	●	●	●
	Air Conditioner for Electric Cabinate	○	○	○	○	○
Tool Magazine	Arm Type High Speed Automatic Tool Changer	●	●	●	●	●
	24 Tool ATC	●	●	●	-	-
	30 Tool ATC	-	-	-	●	●
Coolant & chip management	Inbuilt tank mounted CTS system with max.20 bar pressure	○	○	○	○	○
	Oil Coolant Separator	●	●	●	●	●
	Chip Flushing System	●	●	●	●	●
	Rear Side Chip Outlet	●	●	●	●	●
	Ring Coolant	●	●	●	●	●
	Progammable Coolant Nozzles	○	○	○	○	○
	Mist oil lubrication sprayer	○	○	○	○	○
	Scraper Conveyor With Drum filter	○	○	○	○	○
	Slat Type Conveyor	○	○	○	○	○
4th Axis/ 5th Axis	4 th / 5 th Axis Ready	○	○	-	○	○
	4 th / 5 th Axis interface with Drive	○	○	-	○	○
	CNC Rotary Tables (Range of Tables) / Tilting Rotary Table	○	○	-	○	○
Tool Measuring System	Renishaw LTS	○	○	○	○	○
	Renishaw Primo Kit	○	○	○	○	○
Others	Manual Pulse Generator	●	●	●	●	●
	Air Gun & Coolant Gun	●	●	●	●	●
	Machine Operation & Maintenance Manuals	●	●	●	●	●
	Automatic Lubrication System	●	●	●	●	●

*Without Zenez HMI | Extended Lead Time Applicable

4th / 5th Axes Tables & Production System

ROTARY MANUFACTURING SYSTEM

- Ideal for multi face machining in single setup.
- Rigid slave table ensures stability during machining at heavy load.
- Option of rotary union for hydraulic and pneumatic fixtures.
- Option of side support in lieu of Slave Table.

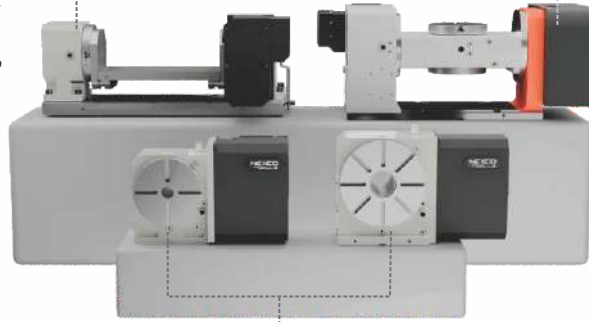

CNC TILTING ROTARY TABLE

- Full flexibility with $\pm 110^\circ$ Tilting Angle.
- Ideally suited for machining at compound angle for medical and aerospace industries.
- Universal Base Plate for T-Slot pitches of 100mm, 125mm and 150mm.



End Support

Slave Table

- SLT-200/250 (Pneumatic/Hydraulic)

CNC ROTARY TABLE

- High Speed Rotation @ 33.3rpm.
- Dual Lead Worm Drive.
- Special Bearing Design.



Tailstock

- TSA-160/185
(Manual/Pneumatic/Hydraulic)

Zero Backlash Roller Cam Tables



Roller Cam Driver

- Rotary Tables Available with Roller CAM Driver as Option.



4th Axes Rotary Tables



Tilting Rotary Tables

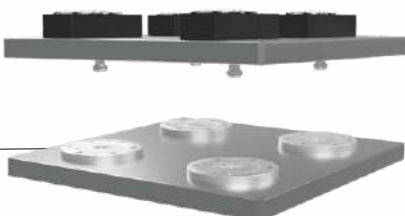

Advanced Fixture Solutions

ZERO POINT SYSTEM

Key Benefits

- **Instant Setup & Changeover**
Reduce machine downtime with quick and effortless clamping.
- **High Repeatability Accuracy**
Ensures micron-level positioning every time you load a part.
- **Powered by AMF**

Auto Tending Machining Center

Automill : The Future of Manufacturing, Simplified

Key Features

- No Programming Required.
- Quick Part Changeovers.
- 3D Visualisation.
- Fast and Accurate Calibration.
- Smart Task Automation.
- Collision Avoidance.

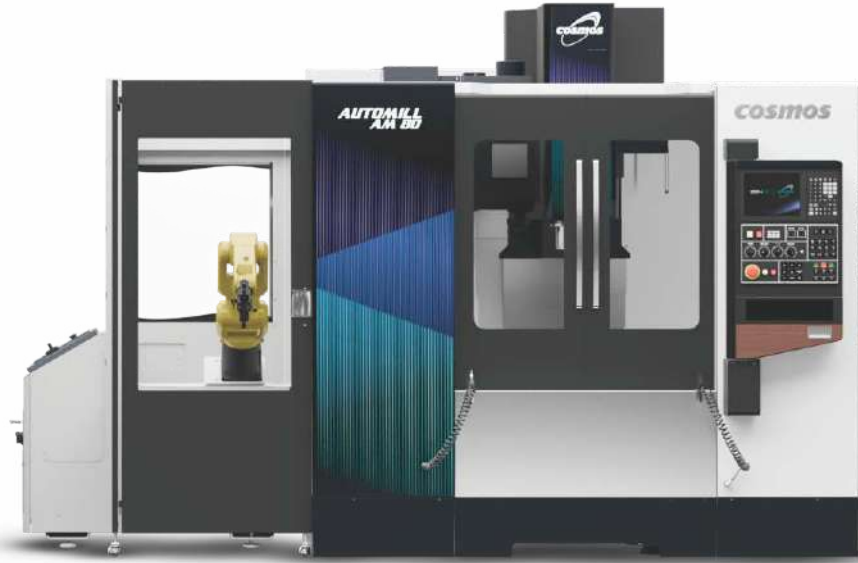

The AutoMill Series is an **all-in-one, self-loading machining system** designed to simplify complex manufacturing workflows. It integrates high-performance hardware with an intuitive "Easy Management" interface, allowing operators to achieve greater precision with minimal manual intervention.

By effectively bridging the gap between hardware and software, the system provides a flexible solution that maintains high speed and consistency across both large-scale production runs and agile, varied projects. Ultimately, the AutoMill is engineered to scale output and maximize overall facility productivity.

ROBORATOR VI 5

Designed for high speed robotic loading & unloading.

7 Kg 6th Axis Robot



5 Drawers

(600mm X 400mm X 80mm)

AVNI

Designed to handle two machines with a single robot.

12 kg 6th Axis Robot
(optional 25 kg and 35 kg capacities)



800x600x100mm

(Optional 1000x800x100mm)

All-in-One Digital Data Monitoring Solution for Manufacturing Industries

What is digifac?

The digiFAC is an IIoT (industrial IoT) platform that can integrate various signals from all kinds of controller-based machines, including CNCs, Injection Moulding Machines, and Press Machines, and analyze them automatically to generate accurate real-time reports. With the least human intervention, it collects the information directly from the machines and helps you get the maximum benefit from your assets and enhance productivity.

Why digifac?

- Industry-Leading: Production efficiencies and agility.
- Highly expert team members.
- Phenomenal solutions to take your company to the next level.
- User-friendly Interface; use features as per dedicated roles/users.
- Transparent, quick, and real-time data availability that can help you make fast decisions.
- To improve OEE.
- Increase your productivity by 20%.
- ROI within 3-4 months.
- To maintain your OTD.
- To reduce lead time, setting time, and deliver on time.



*Available as option.

Digifac Software Features



Dashboard Monitoring

- ▶ Live information of the entire factory.
- ▶ Categorise machines (Unit-wise).
- ▶ View regular Utilisation of the machine.



Alarm Analysis

- ▶ Alarm history by code or machine.
- ▶ Time and duration of all alarms generated by a separate machine.



Tool Cutting Time Information

- ▶ No more unidentified dry-runs.
- ▶ Program path optimisation in-sight.
- ▶ Tool usage clarity.



Production Information (Utilisation)

- ▶ Detailed production information report.
- ▶ An automated daily production report.
- ▶ All reports are available in Excel format.



Downtime Analysis

- ▶ See total machine downtime.
- ▶ Monitor downtime and the reasons for it (Macro Downtime Feature).
- ▶ Focus and can easily get the classified major losses/downtimes and work on optimisation.



Email Alerts

- ▶ Set a time for machines' idle condition and receive or get alarm notification on email.
- ▶ Management Reporting: Receive daily production report and downtime analysis report by email on daily basis.

Other Product Range

CVM SERIES



High Performance Machining Centres

TAPMILL SERIES



High Speed Milling & Taping Center

DYNAMILL SERIES



Monoblock Machining Center

V-TURN SERIES



Vertical Turning Lathe

GRINDING SERIES



Precision Surface Grinding Machines

MEGAMILL SERIES



Double Column Machining Center

YOUR PARTNER IN
PROGRESS 

For PAN India Sales and Services Support

+91-966 2044 983

Vadodara and MP

+91 70437 35005

Ahmedabad

+91 95129 80022

Rajkot and Saurashtra

+91 99740 61567

**Pune, Kolhapur, Belgaum
& Ch. Sambhaji Nagar**

+91 98509 89476

Mumbai

+91 70308 77977

South Gujarat

+91 75740 01763

Nashik

+91 96378 27722

Delhi & NCR

+91 93500 50200

Noida & Ghaziabad

+91 93500 75724

Gurgaon & Bhiwadi

+91 98107 05724

Faridabad

+91 95999 10370

Punjab

+91 98107 05736

+91 93500 50200

Bengaluru

+91 99022 00025

Hyderabad

+91 75670 80452

Chennai

+91 74859 12550

Coimbatore and Keralam

+91 75748 23720



cosmos[®]

Corporate Office

Cosmos House, Plot No. 85/2, Padra Road, Atladara, Vadodara, Gujarat - 390 012

Manufacturing Facilities

Plant - I

Cosmos Impex (India) Pvt. Ltd., Plot No. 847, 848 Village Ranu, Ta. Padra, Vadodara, Gujarat - 391 445

Plant - II

Plot No. 68-B, Sigil Compound, Padra Road, Atladara, Vadodara, Gujarat - 390 012

+91 63582 47046 ✉ sales@cosmos.in 🌐 cosmos.in

***Kindly Note:** These products are under revision for specifications upgrades.

Request to kindly visit cosmos.in to get all the latest information about our complete product range.

